

GAS FILTER 1/2", 3/4", 1" – Small capacity – Pmax 6 bar



Code	Description	Dimension	Pmax
GF015SC	Gas filter small capacity	1/2"	6 bar
GF020SC	Gas filter small capacity	3/4"	6 bar
GF025SC	Gas filter small capacity	1"	6 bar

TECHNICAL FEATURES

Operation maximum pressure	6 bar
Working Temperature	- 20 °C – + 60 °C
Filtration	≤ 50 Micron
Use	Non – aggressive gases – Family 1 – 2 – 3 and air Special version for Biogas
Cartridge element	Plastic cartridge PP
Connection	1/2" – 3/4" – 1" Wall boiler – ISO 228
Complete Body	Die – Cast Aluminium Gd – AlSi12Cu – EN AB 46100
Seals	NBR
Approval	PED

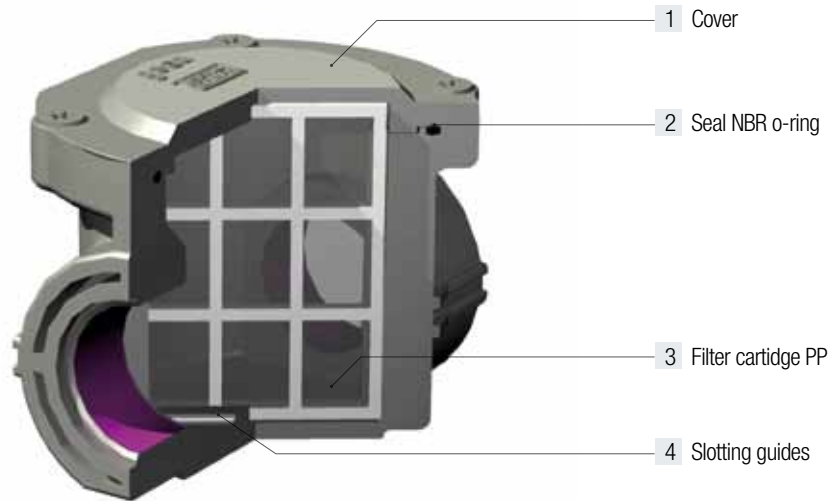

FLOW CHART

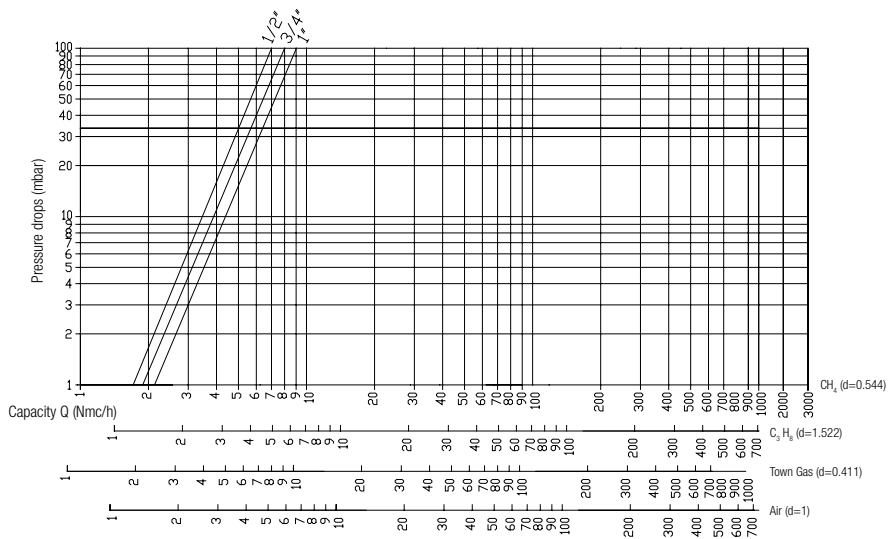

DIMENSIONS (mm) and WEIGHT (kgs)				
Dimension	A	B	C	Weight
1/2"	72	60	65	0,221
3/4"	72	60	65	0,212
1"	72	60	65	0,199

